



# Coupling Solutions

---

# ABOUT AniGears™



AniGears™ Engineering Solutions is a leading Indian manufacturer engaged in the design, development, and production of mechanical power transmission and material handling products, specializing in industrial couplings, pulleys, and conveyor components.

Established in 2007, AniGears™ began its journey as Transpower and evolved in 2023 into a full-fledged manufacturing brand with a renewed focus on engineering precision, product innovation, and superior quality.

With a strong commitment to precision, performance, and dependability, AniGears™ has become a trusted partner to major industries including Steel, Cement, Power, Mining, Paper, and Heavy Engineering.

Our products are the outcome of advanced design practices, high-grade materials, and controlled manufacturing processes, ensuring optimum torque transmission, enhanced misalignment capacity, and vibration-free operation across all applications.

We believe every connection we engineer — whether a coupling, pulley, or conveyor solution — plays a vital role in keeping industries in motion: efficiently, reliably, and safely.

AniGears™ is a brand built on engineering strength, manufacturing excellence, customer trust, and a pursuit of quality without compromise.

## Manufacturing Excellence

AniGears' manufacturing facility is strategically located in the midst of Gujarat, India's engineering powerhouse. Spanning over 49,850 sq. ft., the facility is equipped with advanced machining, inspection, and coating infrastructure, enabling consistent quality and large-scale production.

- ✓ CNC Turning, Milling, and Gear Hobbing Machines
- ✓ Dynamic Balancing and Runout Testing Systems
- ✓ In-house CED Coating & Phosphating Lines
- ✓ Dedicated Quality Inspection & Assembly Bays
- ✓ Laser Marking & Traceability

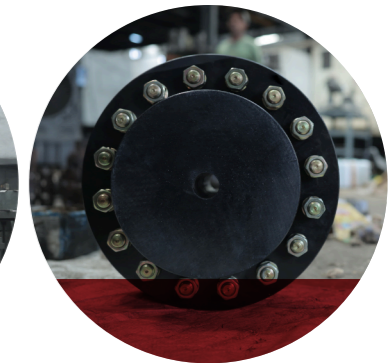
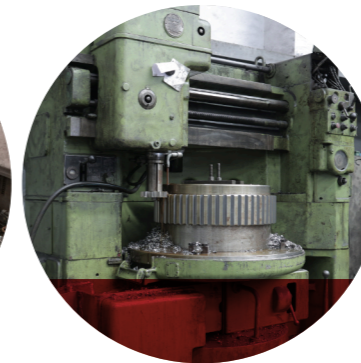
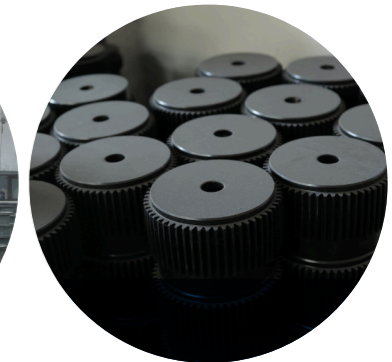
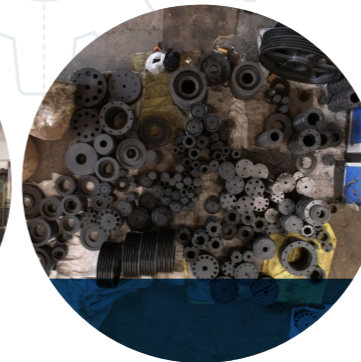

## Vision

To be recognized as a trusted and innovative Indian brand in mechanical power transmission, delivering world-class coupling solutions that drive industries forward through reliability, standardization, and technological advancement.

## Mission

To provide engineering-driven, performance-focused, and cost-effective coupling solutions that ensure uninterrupted power transmission and machine reliability, while building long-term partnerships through technical excellence and service integrity.



## Core Value

- ✓ **Precision:** Every product we manufacture is machined to the finest tolerances, ensuring smooth operation and dependable fitment.
- ✓ **Integrity:** We conduct every business with honesty, accountability, and transparency — creating value through trust.
- ✓ **Innovation:** Continuous product enhancement through modern design tools, simulation, and field performance feedback.
- ✓ **Commitment:** A promise to deliver quality, reliability, and consistency in every order, every time.
- ✓ **Customer Focus:** Understanding customer applications deeply to deliver tailored and efficient engineering solutions.

## Design & Engineering Philosophy

At **AniGears™**, engineering is not a process — it's a philosophy. Every product is developed through a structured, application-oriented approach designed to achieve precision, balance, and reliability.

This rigorous process ensures that every AniGears coupling meets or exceeds international standards in performance and durability.

*Our engineering philosophy combines precision craftsmanship with modern manufacturing — making AniGears a symbol of trust in power transmission.*

## Our Design Process

### Requirement Analysis

Understanding torque, speed, load fluctuations, and operating conditions.

### Design Simulation

Using CAD, 3D modeling, and finite element analysis to ensure optimized geometry and strength.

### Material Selection

Choosing certified steels and elastomeric compounds suitable for mechanical and environmental stress.

### Controlled Machining

Multi-stage CNC processes ensuring accurate dimensions and interchangeability.

### Quality Validation

Dimensional checks, torque tests, and dynamic balancing before coating and dispatch.

### Surface Protection

Advanced CED Coating / Phosphating for corrosion resistance and longevity.

## Quality & Reliability

Quality at **AniGears™** is an integrated practice — embedded in every stage of production. From raw material to final dispatch, every coupling undergoes multiple inspections for:

- ✓ Dimensional Accuracy
- ✓ Hardness & Surface Integrity
- ✓ Alignment & Balancing
- ✓ Torque & Misalignment Testing
- ✓ Coating Thickness & Adhesion

Our objective is simple: **zero defect manufacturing and 100% operational reliability** in every product delivered.

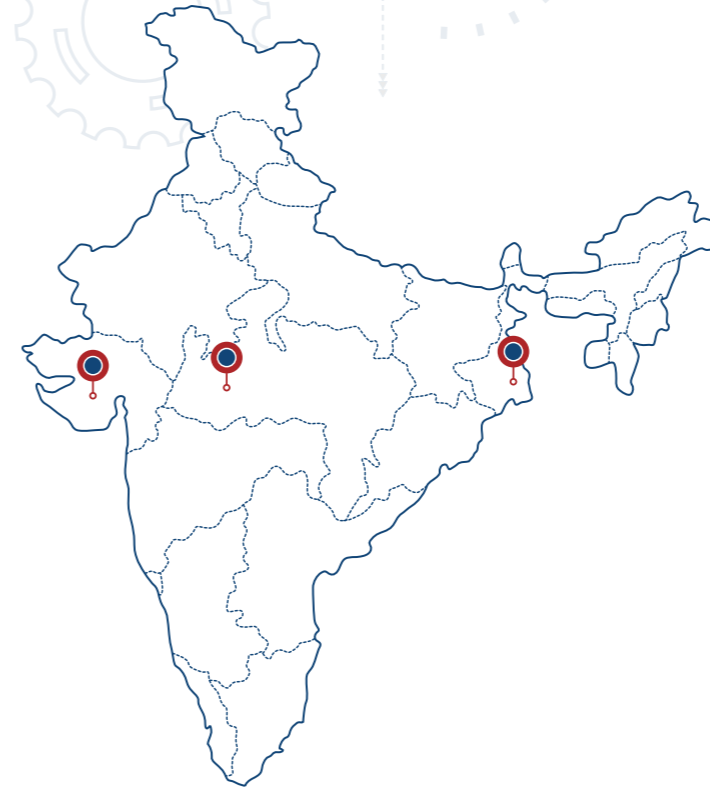

## Nationwide Presence

With manufacturing and operational based in West Bengal, Gujarat, Madhya Pradesh, **AniGears™** serves industries across Eastern, Western, and Central India, supported by a dedicated team of technical and sales engineers.

We provide complete assistance — from product selection and sizing to installation and after-sales service — ensuring every client experiences the consistent performance and reliability that **AniGears™** stands for.



## Associated Brand – AniFlex™

While **AniGears™** is focused on industrial couplings and engineered products, our associated brand **AniGears™** is engaged in pulleys, conveyor belts, and belt drive solutions, carrying forward the legacy of KhaitanFlex with enhanced technology and quality.

Our conveyor belts are manufactured in Madhya Pradesh, following stringent quality control and precision manufacturing standards to ensure long-lasting and efficient performance across diverse industrial environments.



For pulleys, belts, and drive solutions, contact:

-  [www.anigears.com](http://www.anigears.com)
-  [works@anigears.com](mailto:works@anigears.com)

## GEAR COUPLINGS (AG & EA SERIES)

AniGears Gear Couplings (AG and EA Series) are high-performance, torsionally rigid, flexible shaft couplings designed to transmit high torque between rotating shafts operating under demanding industrial conditions.

Torque is transmitted through accurately machined, hardened, and crowned gear teeth on the hubs, which engage with internal teeth on the sleeves. This design permits limited angular, parallel, and axial misalignment while maintaining compact dimensions and high torque capacity.

The AG Series (FGC Type) represents the heavy-duty range of Full Gear Couplings, available in Short Teeth (ST) and Long Teeth (LT) configurations to suit different torque and alignment requirements.

The EA Series (ED Type) are standard gear couplings, compact in design, ideal for general-purpose industrial drives.

AniGears gear couplings are precision-engineered and supplied fully CED-coated for corrosion protection and long service life.

They are widely used in steel, cement, mining, power, and process industries, offering reliable operation and minimal maintenance over prolonged service periods.



## Construction & Materials

Component	Material / Specification	Function / Description
Hubs	Forged Carbon Steel (EN-8 / EN-9)	Machined and gear-cut with crowned external teeth. Transmit torque through meshing with sleeve teeth.
Sleeves (AG-101 to AG-110)	Fully Forged Carbon Steel (EN-8)	High-strength forged sleeves ensure maximum fatigue resistance and long life under cyclic torque loading.
Sleeves (AG-111 & above)	Medium Carbon Cast Steel with Induction-Hardened Teeth	Large-size sleeves designed for high torque and wear resistance under continuous operation.
Sleeves (EA Series)	Medium Carbon Steel / Cast Steel	Compact design for general-purpose drives, precision-bored for accurate alignment.
Seals	Nitrile Rubber (NBR)	Prevent grease leakage and entry of dust or contaminants. Maintain lubrication integrity.
Gaskets / Retaining Rings	Rubberized Steel / Mild Steel	Retain lubricant and seal the hub-sleeve interface.
Fasteners	High Tensile Steel (Grade 8.8), CED-Coated	Provide secure assembly and resist corrosion.
Lubricant	Lithium-based High-Temperature Grease (EP2 or Equivalent)	Ensures smooth engagement and minimizes wear.
Surface Finish	Cathodic Electrode Deposition (CED)	Provides uniform and long-lasting corrosion resistance.

**Note:**

All couplings are dynamically balanced and supplied pre-machined for precise concentricity and vibration-free operation.

AG Series hubs and sleeves are supplied in matched pairs for precise gear tooth contact.

## Applications

- ✓ Steel rolling mills, bar and rod mills
- ✓ Cement crushers, rotary kilns, and conveyors
- ✓ Power plant fans, turbines, and pumps
- ✓ Mining equipment, mixers, and material handling systems
- ✓ Heavy industrial drives and mechanical transmissions.

## Advantages Summary

- ✓ High torque capacity with compact construction
- ✓ Excellent torsional rigidity and precise torque transmission
- ✓ Accommodates angular, parallel, and axial misalignments
- ✓ Available in Short and Long Tooth configurations
- ✓ Fully enclosed, grease-lubricated design ensures longer life
- ✓ All metallic components CED-coated for superior corrosion protection
- ✓ Interchangeable with standard industry coupling dimensions.

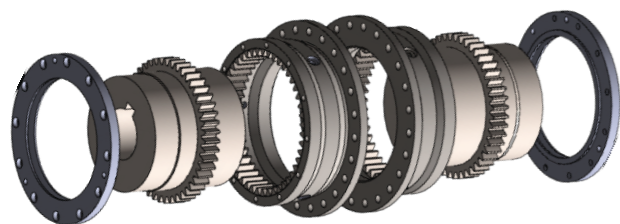

## Design & Operating Features

### High Torque Density

Compact and robust design ensures high torque transmission capability relative to coupling size.

### Crowned Gear Teeth

External hub teeth are crowned to ensure uniform load distribution, reducing edge contact and stress under misalignment.

### Double Engagement Flexibility

Allows simultaneous accommodation of angular, parallel, and axial misalignments without inducing excessive bearing load.

### Short Teeth (ST)

Allow greater angular flexibility and are recommended for drives where misalignment variations or shaft deflections are expected.

### Long Teeth (LT)

Provide higher torque capacity and improved load distribution due to larger contact area but allow slightly lower misalignment.

### Torsional Rigidity

Metallic tooth engagement ensures positive torque transmission with negligible torsional wind-up, suitable for high-speed drives.

### Ease of Maintenance

Seals can be replaced without disturbing hubs. Lubrication through grease nipples simplifies periodic servicing.

### CED-Coated Protection

All metallic components are CED-coated for uniform rust protection and extended service life.

### Fail-Safe Design

Even under lubricant loss or seal deterioration, torque transmission continues temporarily through metallic contact, preventing drive interruption.

## Performance Characteristics

Parameter	AG & EA Series
Nominal Torque Capacity	Up to 150,000 N·m
Speed Range	Up to 4,000 RPM (depending on size)
Angular Misalignment	± 0.5° per half coupling (ST / EA), ± 0.35° (LT)
Parallel Misalignment	Up to 0.25 mm (ST / EA), Up to 0.20 mm (LT)
Axial Float	± 3 mm (ST / EA), ± 2 mm (LT)
Service Factor Range	1.0 – 2.5
Temperature Range	-20 °C to +80 °C
Lubrication Type	Grease (Lithium-based EP2 or equivalent)

## Service Factor Table

Type of Application	Nature of Load	Service Factor (SF)
Centrifugal Pumps, Fans, Line Shaft Drives	Uniform	1.0 – 1.3
Agitators, Conveyors (Moderate Shock)	Moderate	1.4 – 1.7
Crushers, Mixers, Compressors	Heavy	1.8 – 2.2
Vibrating Screens, Rolling Mills	Severe	2.3 – 2.5

### Note:

- ✓ Add +0.25 for internal combustion engine drives.
- ✓ Add 10% for operation exceeding 10 hours per day.
- ✓ Select the next larger coupling size for reversing or frequent start/stop drives.

## Selection Procedure

- ✓ **Step 1 — Determine Absorbed Power**  
Identify the absorbed power (kW) or torque of the driven machine under normal conditions.  
If torque is known:  
 $P = 2\pi NT / 60,000P$
- ✓ **Step 2 — Select Service Factor**  
Choose the Service Factor (SF) from the table above according to drive type and duty cycle.  
Design Power = Absorbed Power × Service Factor
- ✓ **Step 3 — Select Coupling Size**  
From the combined Power & Dimension Table, select the first coupling size whose rated power at the operating speed equals or exceeds the calculated Design Power.  
For the AG Series:  
ST (Short Teeth): preferred for higher misalignment flexibility.  
LT (Long Teeth): preferred for higher torque and uniform load drives.
- ✓ **Step 4 — Check Bore Range and Misalignment**  
Confirm that both shaft diameters fall within the permissible bore range and that expected misalignments are within allowable limits
- ✓ **Step 5 — Confirm Lubrication and Speed**  
Ensure coupling speed and lubrication conditions comply with rated values for the selected size.

## Dimension Of AG SERIES

Coupling No / Size	Power at 100 rpm	Maximum Torque	Maximum Speed RPM	Hub Bore (mm)			Dimensions (mm)										Approx. Weight in Kg.		Clamping Bolt Size	No. of Bolts
				Min.	Max Flex	Max Rigid	A	B	D	E	F	G	G1	H	J	Full Flex	Half Flex			
AG-101	11.5	1100	6700	14	55	60	170	115	17	55	5	78	90	110	65	11	10.5	M12 X 50	6	
AG-102	28.5	2720	6100	20	60	75	185	145	17	70	5	85	110	125	85	16	15	M12 X 50	6	
AG-103	51.5	4920	5200	30	75	90	220	175	20	85	5	107	130	150	105	26	26	M16 X 60	6	
AG-104	96.5	9220	4500	40	100	110	250	215	20	105	5	138	160	178	125	41	42	M16 X 60	8	
AG-105	150	14320	3950	46	120	130	290	240	25	115	10	166	185	204	140	63	63	M20 X 75	8	
AG-106	230	21960	3500	50	125	150	320	260	25	125	10	176	215	230	155	86	87	M20 X 75	8	
AG-107	390	37250	3250	60	145	170	350	290	25	140	10	208	240	260	175	120	120	M20 X 75	10	
AG-108	515	49180	3000	70	165	200	380	330	25	160	10	230	285	290	200	165	170	M20 X 75	12	
AG-109	644	61500	2600	80	200	220	430	340	25	165	10	270	315	332	210	210	220	M24 X 80	10	
AG-110	930	88800	2300	100	230	260	490	370	25	180	10	315	370	390	230	310	320	M24 X 80	12	
AG-111	1265	120800	2100	110	260	280	545	410	30	200	10	350	380	445	270	454	430	M24 X 90	12	
AG-112	1600	152800	1900	150	300	310	590	490	30	240	10	404	420	490	300	630	590	M24 X 90	14	
AG-113	2880	275000	1550	160	330	340	680	535	35	260	15	442	480	555	320	887	850	M30X110	14	
AG-114	3980	380000	1400	200	370	370	730	575	35	280	15	500	520	610	340	1097	1050	M30X110	16	
AG-115	4765	455000	1350	230	410	400	780	655	35	320	15	540	560	660	385	1440	1350	M30X110	18	
AG-116	6800	650000	1150	260	450	460	900	720	45	350	20	630	650	755	425	2120	2000	M36X130	18	
AG-117	9000	850000	1050	300	520	530	1000	820	45	400	20	720	750	855	490	3100	2900	M36X130	20	
AG-118	11800	1120000	950	320	620	580	1100	920	55	450	20	820	820	950	535	4370	4050	M36X150	20	
AG-119	15500	1470000	825	400	710	700	1250	1000	55	485	30	915	920	1050	560	5590	5200	M48X165	20	

## Installation Steps

- ✓ Clean all components to remove dust, oil, and protective coating.
- ✓ Mount hubs on shafts with proper key fits ensuring full key engagement.
- ✓ Align hubs maintaining the required end float (axial gap) as per the dimension table.
- ✓ Insert seals and fill coupling cavity with grease (EP2 type) up to 75% of volume.
- ✓ Assemble sleeves over hubs ensuring full gear engagement.
- ✓ Install gaskets and retaining rings, tighten bolts evenly in a diagonal pattern.
- ✓ Check alignment using feeler gauge or dial indicator after assembly.

## Lubrication

- ✓ Use Lithium-based EP2 grease or equivalent.
- ✓ Re-lubricate every 3,000–4,000 operating hours or during scheduled shutdowns.
- ✓ Replace seals if hardened, cracked, or damaged.

## Maintenance

- ✓ Inspect for grease leakage and seal wear periodically.
- ✓ Replenish or replace lubricant as necessary.
- ✓ For high-speed drives (>3000 RPM), maintain balance grade G 6.3 or better.
- ✓ Maintain misalignment within permissible limits to prevent premature wear.

## Notes

- ✓ Ratings apply to continuous operation at 50 °C ambient temperature.
- ✓ For reversing or heavy shock loads, multiply absorbed power by applicable Service Factor.
- ✓ For low-speed drives (<100 RPM), select based on torque rating.
- ✓ Maintain misalignment within 50% of permissible limits for longer life.
- ✓ All metallic components are CED-coated for long-term corrosion resistance.
- ✓ For vertical or special-duty applications, consult AniGears Technical Department.

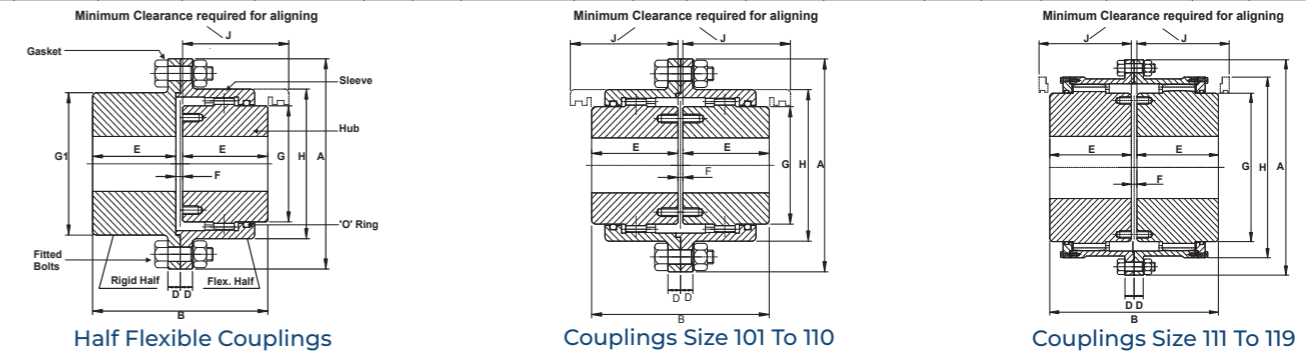

## Dimension Of EA SERIES

Size	Nominal Torque Nm	Max Torque Nm	Pilot Bore	Max Bore mm	A mm	C mm	D mm	L mm	M mm	N1 mm	max ang deg		Weight	MR*2	Bolt
											ang deg	parallel +/-			
EA130	1300	2600	10	45	111	67	80	43	74	3	2*0.75	0.35	4	0.005	6*M8
EA 280	2800	5600	15	60	141	87	103.5	50	84	3	2*0.75	0.4	7	0.015	8*M10
EA 500	5000	10000	25	75	171	106	129.5	62	105	3	2*0.75	0.5	14	0.039	6*M12
EA 1000	10000	20000	30	95	210	130	156	76	123	3	2*0.75	0.6	25	0.101	6*M12
EA 1600	16000	32000	35	110	234	151	181	90	148	5	2*0.75	0.7	37	0.188	8*M16
EA 2200	22000	44000	50	130	274	178	209	105	172	5	2*0.75	0.9	60	0.431	8*M16
EA 3200	32000	64000	60	155	312	213	247	120	193	6	2*0.75	1	90	0.845	12*M16
EA 4500	45000	90000	75	175	337	235	273	135	215	6	2*0.75	1.1	118	1.322	12*M16
EA 6200	62000	124000	85	195	380	263	307	150	241	8	2*0.75	1.2	169	2.45	16*M16
EA 8400	84000	168000	95	215	405	286	338	175	279	8	2*0.75	1.4	224	3.72	16*M16
EA 11500	115000	230000	115	240	444	316	368	190	304	8	2*0.75	1.5	277	5.39	12*M20
EA 17400	174000	348000	145	275	506	372	426	220	339	10	2*0.75	1.7	414	10.88	16*M20

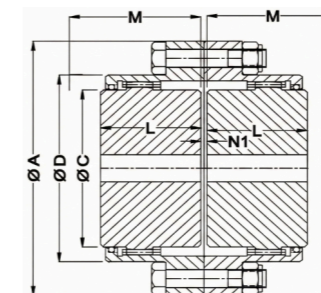

M - Alignment Control Dimension

## PIN BUSH COUPLING

AniGears Pin-Bush Couplings are highly reliable, torsionally flexible couplings designed to transmit torque through a set of resilient rubber bushes mounted between two flanged hubs.

Each bush acts as a flexible link between the driving and driven pins, enabling the coupling to absorb shocks, damp vibrations, and compensate for small angular, parallel, and axial misalignments in connected shafts.

AniGears offers two design variants:

- ✓ **AP Series (Standard Pin-Bush Type):**  
Equivalent to BC-type couplings, using cylindrical rubber bushes for medium-duty industrial drives.
- ✓ **AB Series (Barrel Bush Type):**  
Equivalent to B-Flex type couplings, featuring specially contoured barrel-shaped bushes that provide enhanced misalignment capacity and superior shock absorption, making them ideal for heavy-duty and reversing drives.

Both designs ensure smooth, noiseless operation and long service life even under demanding operating conditions. They are simple in construction, easy to install, and require no lubrication, thereby ensuring maintenance-free service.

## Applications

AniGears Pin-Bush Couplings are suited for applications involving moderate to heavy shock loads, reversing torques, and frequent starts/stops.

Typical installations include:

- ✓ Centrifugal and slurry pumps
- ✓ Belt and screw conveyors
- ✓ Crushers, mixers, and agitators
- ✓ Fans and blowers
- ✓ Textile and paper machinery
- ✓ Rolling mills, cement plants, and general industrial drives



## Construction & Materials

Component	Material / Specification	Function / Description
Hubs / Flanges	High-grade Cast Iron (IS 210 FG 260)	Precision-machined hubs with accurately drilled pin holes ensure concentricity and uniform torque distribution. Steel hubs available on request for heavy drives.
Pins & Nuts	High Tensile Steel (8.8 Grade) – CED Coated	Hardened and ground pins transmit torque through bushes. CED coating ensures corrosion resistance and long life.
Bushes	Natural Rubber Compound (vulcanized), bonded with steel sleeves	Absorbs misalignment and vibration. Bushes are replaceable without disturbing hubs.
AP Series Bushes	Cylindrical Rubber Bushes	Suitable for moderate misalignment and medium torque drives.
AB Series Bushes	Barrel-Shaped Rubber Bushes	Allows higher angular/parallel offset and better damping for heavy-duty drives.
Bolts / Hardware	High Tensile, CED Coated	Uniform clamping pressure, corrosion resistant.
Surface Finish	Cathodic Electrode Deposition (CED)	All metallic parts are CED-coated for superior corrosion protection and finish.
Lubrication	Not Required	Dry-type flexible coupling.
Temperature Range	-30 °C to +70 °C	Suitable for most industrial environments.

## Performance Characteristics

Parameter	AP Series (Standard Pin-Bush)	AB Series (Barrel Bush)
Nominal Torque Capacity	Up to 15,000 Nm	Up to 25,000 Nm
Speed Range	Up to 2000 RPM	Up to 2500 RPM
Angular Misalignment	±2°	±3°
Parallel Misalignment	±2 mm	±3 mm
Axial Misalignment	±1.5 mm	±2 mm
Service Factor Range	1.0 – 2.5	1.25 – 3.0
Temperature Range	-30 °C to +70 °C	-30 °C to +70 °C



## Design & Operating Features

### Torsional Flexibility

The rubber bushes deform under load, reducing transmission of shock and torque fluctuations.

### Vibration Damping

The flexible medium absorbs vibrations, reducing noise and extending equipment life.

### Fail-Safe Operation:

Even under extreme overload or bush failure, metallic contact allows limited torque transmission to protect against total drive interruption.

### No Lubrication Required:

Simplifies maintenance, prevents contamination, and ensures clean operation.

### Misalignment Compensation

Capable of accommodating angular, parallel, and axial misalignments without imposing excessive reactionary forces on shafts or bearings.

### Ease of Maintenance

Bushes are replaceable without disturbing the hubs or connected shafts.

### High Misalignment Capacity

AP Series: Angular  $\pm 2^\circ$ , Parallel  $\pm 2$  mm  
AB Series: Angular  $\pm 3^\circ$ , Parallel  $\pm 3$  mm

### CED-Coated Hardware

Uniform coating ensures rust protection even in humid or outdoor environments.

## Selection Procedure

- ✔ **Step 1**  
Identify absorbed power (kW) and speed (RPM) of the driven equipment.
- ✔ **Step 2**  
Choose the Service Factor from the table above, considering the prime mover type (electric motor or engine) and the nature of duty (uniform, moderate, heavy, or shock load).
- ✔ **Step 3 - Compute Design Power**  
Design Power = Absorbed Power  $\times$  Service Factor
- ✔ **Step 4 - Select the Coupling Size**  
From the combined Power + Dimension Table, locate the coupling size whose Power @ 100 RPM, when corrected for the actual operating speed, is equal to or greater than the calculated Design Power. Corrected Power = Power @ 100 RPM  $\times$  N/10
- ✔ **Step 5 — Confirm Lubrication and Speed**  
Ensure coupling speed and lubrication conditions comply with rated values for the selected size.
- ✔ **Step 6**  
Verify Misalignment Limits for the layout and confirm that the expected angular, parallel, and axial offsets are within allowable values.
- ✔ **Step 7**  
For frequent start/stop, reversing, or highpeak-torque applications, select the next larger coupling size to provide an additional safety.

## Service Factors

Use these factors with absorbed power to obtain Design Power = Power  $\times$  Service Factor.

Type of application	Service Factor
Centrifugal pumps (even load), apron/belt/screw conveyors – horizontal, line shafting, woodworking (light)	1.0–1.3
Fans (industrial), agitators/mixers (uniform), generators (even load)	1.3–1.7
Rotary/gear/vane pumps, blowers, plastic/rubber extruders, dynamometer, paper mill aux.	1.7–2.0
Screw compressors, bucket elevators, rotary kilns/dryers/screens, hammer mill (cement/mines)	2.0–2.5
Reciprocating pumps/compressors ( $\geq 3$ cyl. = lower end; 1–2 cyl. = higher end), crushers (stone/ore)	2.5–3.5
Hoists/cranes (class-dependent), vibrating screens, steel/rolling-mill drives (wide range)	3.0–6.0

### Note:

- ✔ Add +0.25 for internal combustion engine prime movers.
- ✔ For heavy shock/reversing or frequent starts, multiply resultant by 1.25.
- ✔ For >10 hours/day duty, add ~10% margin.

## AP Series – Standard Pin-Bush Couplings AB Series – Barrel Bush Couplings

These couplings employ cylindrical rubber bushes to provide medium torsional flexibility and moderate misalignment accommodation.

They are designed for general industrial drives involving uniform to moderate shock loads.

Refer to Table AP-01 — Combined Power & Dimension Data (for continuous duty at ambient temperature up to 50 °C).

### Note:

- ✔ Ratings apply to continuous operation up to 50 °C ambient temperature.
- ✔ For reversing or high-shock drives, multiply absorbed power by the appropriate Service Factor before selection.
- ✔ For speeds below 100 RPM, use nominal torque as the limiting factor.

The AB series uses barrel-shaped rubber bushes, providing higher torsional damping, better vibration absorption, and greater angular and parallel misalignment capacity than the standard cylindrical bush type.

They are ideal for heavy-duty, impact, and reversing drives.

Refer to Table AB-01 — Combined Power & Dimension Data (for continuous duty at ambient temperature up to 50 °C).

### Note:

- ✔ Barrel bush design offers enhanced damping and shock absorption.
- ✔ Always select based on Design Power = Absorbed Power  $\times$  Service Factor.
- ✔ For speeds below 100 RPM, torque governs selection.
- ✔ Operates dry; no lubrication required.

## Dimension Of AP SERIES

Coupling Size	Torque Nm	Max. Speed (RPM)	Bore Dia MIN	Bore Dia MAX	QTY N	A	B	C	D	E	F
AP 1	77	6100	12.7	30	3	95	79	38	3	44	58
AP 2	310	5100	12.7	35	4	114	99	48	3	51	70
AP 2A	516	4400	16	45	6	130	105	51	3	67	70
AP 3	621	3600	16	50	4	160	107	51	5	75	114
AP 4	831	3000	20	70	4	191	125	60	5	105	114
AP 4A	1241	3000	20	70	6	191	125	60	5	105	114
AP 5	1662	2600	25	80	6	225	157	76	5	115	114
AP 6	2359	2300	45	100	8	254	183	89	5	140	114
AP 6A	2932	2300	45	100	10	254	183	89	5	140	114
AP 6B	3533	2300	45	100	12	254	183	89	5	140	114
AP 7	4154	1950	55	120	12	290	235	115	5	175	114
AP 7A	5195	1900	55	125	14	300	235	115	5	185	130
AP 8	5816	1850	60	135	16	310	255	125	5	200	130
AP 8A	7268	1650	60	138	18	340	265	130	5	205	130
AP 8B	8729	1590	65	142	12	360	276	135	6	212	200
AP 9	9932	1470	70	152	13	390	316	155	6	225	200
AP 9A	13274	1400	80	162	15	410	336	165	6	240	200
AP 10	14420	1300	90	175	16	440	366	180	6	255	200
AP 10A	18050	1200	100	185	17	480	386	190	6	270	212
AP 11	23780	1080	110	195	20	530	406	200	6	285	212

Table AP-01

## Dimension Of AB SERIES

Coupling Size	Coupling Rating @100 RPM		Max. Speed (rpm)	Min. Bore	Max. Bore		Dimensions					Dimensions in mm			Max. Misalignment ±		
	KW at 100	Torque Nm			ØD1	ØD2	ØA	ØB1	ØB2	G	L	TL	Mass Kg.	M.I.(WR <sup>2</sup> ) In kgm <sup>2</sup>	Axial (mm)	Radial (mm)	Angular
AB-105-3	1	95	7200	11	30	32	105	48	50	2-6	45	94	2	0.003	2	0.3	1°
AB-116-4	1.5	143	6100	12	39	42	116	60	68	2-6	45	94	2.6	0.005	2	0.3	1°
AB-125-4	1.7	162	5500	14	45	50	125	68	78	2-6	50	104	3.1	0.007	2	0.4	1°
AB-144-6	3.3	315	4900	18	50	60	144	82	91	2-6	55	114	4.3	0.012	2	0.4	1°
AB-162-6	5.5	525	4500	22	60	65	162	89	100	2-6	60	124	7.5	0.03	2	0.4	1°
AB-178-6	6.7	640	3800	24	70	75	178	105	115	2-6	70	144	10	0.04	2	0.5	1°
AB-198-10	13	1241	3400	28	80	90	198	124	135	2-6	80	164	13	0.062	2	0.5	1°
AB-228-11	21	2005	3000	28	90	100	228	133	146	4-10	90	187	18	0.1	3	0.6	1°
AB-252-12	32	3056	2700	38	105	115	252	156	167	4-10	100	207	24	0.17	3	0.6	1°
AB-285-11	48	4584	2400	48	115	125	285	170	186	4-10	110	227	35	0.31	3	0.7	1°
AB-320-12	64	6112	2100	55	125	135	320	196	212	4-10	125	257	51	0.53	3	0.7	1°
AB-360-11	93	8881	1900	65	135	150	360	212	232	4-12	140	288	73	1.02	4	0.9	1°
AB400-10	126	12032	1700	75	160	410	400	230	250	4-12	160	328	101	1.7	4	1.1	1°
AB-450-12	195	18621	1500	85	180	450	450	260	290	4-12	180	368	137	2.9	4	1.1	0.5°
AB-500-14	270	25783	1350	95	200	500	500	290	330	4-12	200	408	180	4.7	4	1.1	0.4°
AB-560-10	325	31035	1200	95	225	560	560	320	370	4-8	220	446	278	10.7	2	1.5	0.3°
AB-630-12	440	42017	1050	100	250	630	630	355	410	4-8	240	486	365	17.4	2	1.5	0.3°
AB-710-12	785	74962	950	100	260	710	710	385	450	5-9	260	527	516	33	2	1.8	0.3°
AB-800-14	1047	99981	850	100	280	800	800	420	500	5-9	290	587	691	53	2	1.8	0.3°
AB-900-16	1623	154985	750	100	305	900	900	465	550	5-9	320	647	927	86	2	1.8	0.3°
AB-1000-18	2042	194997	680	125	320	1000	1000	515	600	5-10	350	708	1224	142.8	2	2	0.1°
AB-1120-18	2827	269959	600	135	350	1120	1120	560	660	6-11	380	769	1584	231	2	2.2	0.1°
AB-1250-20	3613	345016	550	150	380	1250	1250	610	720	6-11	420	849	2070	367.5	2	2.4	0.1°
AB-1400-20	5550	529986	490	175	440	1400	1400	700	820	6-12	480	969	3060	693	2	2.7	0.1°
AB-1600-24	7854	750002	430	200	480	1600	1600	770	910	6-12	540	1089	3960	1155	2	3	0.1°
AB-1800-22	10210	974983	380	225	540	1800	1800	870	1020	8-16	600	1212	5760	2205	2	3.4	0.1°
AB-2000-26	13614	1300041	340	250	600	2000	2000	960	1100	8-16	660	1332	7020	3255	2	3.8	0.1°

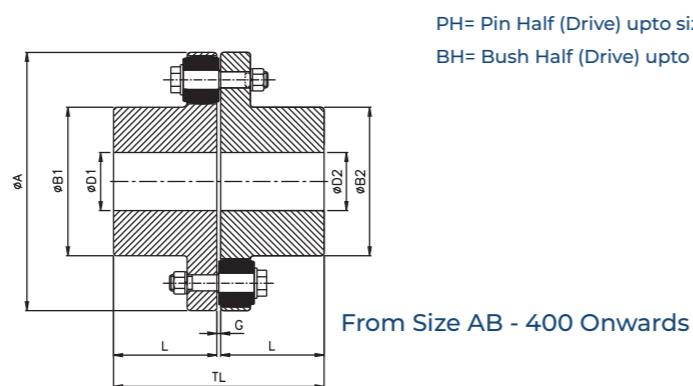
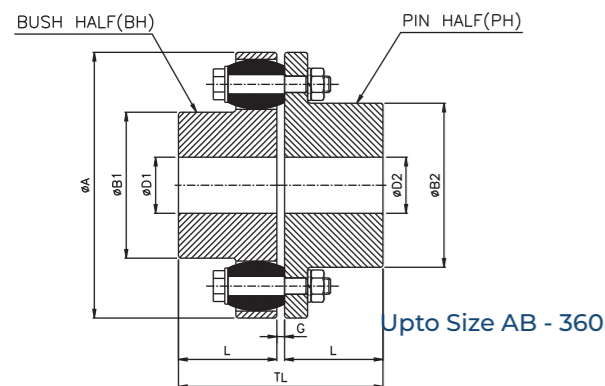

## TYRE COUPLING

AniGears Tyre Couplings are torsionally elastic, highly flexible shaft couplings designed to transmit torque while accommodating angular, parallel, and axial misalignments simultaneously.

The coupling employs a resilient rubber tyre element reinforced with multiple cord layers, securely clamped between two precision-machined metallic flanges. This construction provides excellent shock and vibration damping characteristics and ensures smooth power transmission under varying load conditions.

AniGears Tyre Couplings are particularly suitable for drives subject to cyclic, variable, or reversing torques such as pumps, fans, compressors, conveyors, and general industrial machinery. The couplings operate without lubrication, require minimal maintenance, and provide fail-safe torque transmission even under element fatigue or failure.

The radial tyre fitment design allows easy installation and quick element replacement without disturbing the connected machinery.

## Performance Characteristics

Parameter	Typical Range / Capacity	Remarks
Nominal Torque Capacity	Up to 12,000 Nm	Depends on coupling size and speed.
Speed Range	Up to 4500 RPM	For smaller sizes under balanced operation.
Angular Misalignment	Up to 4°	Total allowable angle between shafts.
Parallel Misalignment	Up to 6 mm	Permitted lateral offset between shafts.
Axial Displacement	±2 mm	Shaft movement absorbed by tyre flexibility.
Service Factor	1.0 – 3.0	As per driven machine classification.
Moment of Inertia (2MR <sup>2</sup> )	Low	Enables smooth start-up and acceleration.
Torsional Flexibility	High	Minimizes transmission of torque peaks.
Maintenance	Minimal	Tyre replaceable without removing hubs.

## Construction & Materials

Component	Material of Construction	Description / Function
Flanges / Hubs	High Grade Cast Iron (IS 210 FG 260)	Precision-machined hubs ensure concentricity and accurate shaft alignment. Designed for uniform load transmission and long fatigue life.
Tyre Element	Natural Rubber Compound	High-grade elastomer reinforced with cord plies. Provides superior flexibility, torsional damping, and shock absorption. Resistant to heat, fatigue, and wear.
Clamping Rings & Fasteners	High Tensile Steel (CED Coated)	Bolts and rings are CED coated for uniform corrosion protection. Ensure uniform clamping pressure and long-term durability.
Surface Coating	Cathodic Electrode Deposition (CED)	All metallic parts are finished with CED coating for high corrosion resistance and consistent appearance.
Hardness (Shore A)	50-70	Optimum hardness to balance torque stiffness and flexibility.
Operating Temperature Range	-50 °C to +60 °C	Suitable for tropical, humid, and industrial environments.
Lubrication Requirement	Nil	Fully dry operation; no lubrication required.

## Selection Procedure

- Step 1 - Determine the Service Factor (SF)**  
 Refer to Table 01 (Service Factor Table) for the combination of driven machine and prime mover. This factor accounts for torque variations, shock loading, and type of duty.
- Step 2 — Calculate the Design Power (P<sub>e</sub>)**  
 Design Power (kW) = Absorbed Power (kW) × Service Factor (SF) Use the actual absorbed power of the driven machine under normal operating conditions.
- Step 3 — Select the Coupling Size**  
 From the combined Power & Dimension Table, locate the coupling whose power rating at the operating speed is equal to or greater than the calculated Design Power.  
  
 The combined table also provides torque, misalignment capacity, and moment of inertia values to assist in engineering evaluation.
- Step 4 — Verify Bore Range**  
 Ensure that both the driving and driven shaft diameters fall within the permissible bore range for the selected coupling size.
- Step 5 — Confirm Misalignment and Speed Limits**  
 Check that the maximum speed and the combined angular, parallel, and axial misalignments of the installation do not exceed the permissible limits specified for the selected coupling.

## Features & Advantages

### Flexible and Torsionally Elastic

Allows simultaneous compensation of angular, parallel, and axial misalignments.

### Vibration and Shock Absorption

The rubber element dampens torsional oscillations and reduces peak torque transmission.

### Fail-Safe Construction

In case of tyre damage, torque can still be transmitted temporarily via interlocking flanges.

### Non-Lubricated Operation

Clean, maintenance-free operation ideal for process industries.

### Quick and Easy Replacement

The tyre can be replaced radially without disturbing connected equipment alignment.

### Reduced Bearing & Seal Load

Flexible damping action reduces reactionary forces and extends machine component life.

### Compact and Balanced Design

Suitable for both horizontal and vertical drives where vibration damping is critical.

## Service Factors

Table 01: Service Factors for Different Prime Movers and Driven Machines (Adapted from Fenner's Reference Standards)

Driven Machine Type	Electric Motor / Steam Turbine	Water Turbine	I.C. Engine Multi-Cylinder	I.C. Engine Single-Cylinder	Steam Engine Single-Cylinder	Diesel Engine Single-Cylinder
Even Torque Machines Generators, Centrifugal Pumps, Blowers, Small Fans, Line Shafting	1.00	1.25	1.50	2.00	2.50	3.00
Machine Tools (Light), Beaters, Exhausters, Woodworking (Light), Alternators, Textile Machines	1.25	1.50	1.75	2.25	2.75	3.25
Multi-Crank Compressors & Pumps, Rotary Dryers, Rotary Screens, Rotary Compressors, Planers, Woodworking (Heavy)	1.50	1.75	2.00	2.75	3.00	3.50
Wire Mills, Cement Mills, Small Printing Presses	1.75	2.00	2.25	3.00	3.25	3.50
Single Crank Compressors & Pumps, Hammers, Ball & Tube Mills, Rolling Mills (Light), Shearing Machines, Crushers, Brick & Stone Machines	2.00	2.25	2.50	3.25	3.50	3.75
Heavy Rolling Mills, Continuous & Reversing Drives, Haulage Loads	2.25	2.50	2.75	3.50	3.75	4.00

### Note:

- For heavy shock or reversing loads, multiply the service factor by 1.25.
- For applications involving frequent starts/stops, allow an additional margin of 0.25 on the service factor.
- For duty cycles exceeding 10 hours/day, increase the service factor by 10%.

## Installation Steps

- ✓ Clean all components thoroughly and remove any protective coating, oil, or dust.
- ✓ Mount flanges on their respective shafts using proper keys and secure fitment.
- ✓ Align shafts, maintaining correct air gap and parallelism (refer to the dimension table).
- ✓ Fit the tyre over both flanges, ensuring the beads are properly seated in the retaining grooves.
- ✓ Tighten all clamping bolts alternately and evenly to the specified torque values.
- ✓ Recheck shaft alignment after final tightening.

## Maintenance

- ✓ Inspect the tyre periodically for cracks, cuts, or deformation.
- ✓ Replace if signs of hardening, wear, or deterioration are observed.
- ✓ Re-torque clamping bolts every 6 months in normal service.
- ✓ Keep the coupling area clean and free from oil, grease, or solvent contact.

## Notes

- ✓ Ratings are based on continuous operation at ambient temperatures up to 50 °C.
- ✓ For intermittent, reversing, or shock loads, multiply absorbed power by the applicable Service Factor.
- ✓ For speeds below 100 RPM, use nominal torque as the limiting factor.
- ✓ Ratings assume correct installation and alignment as per the recommended procedure.

## Dimension Of Tyre Couplings

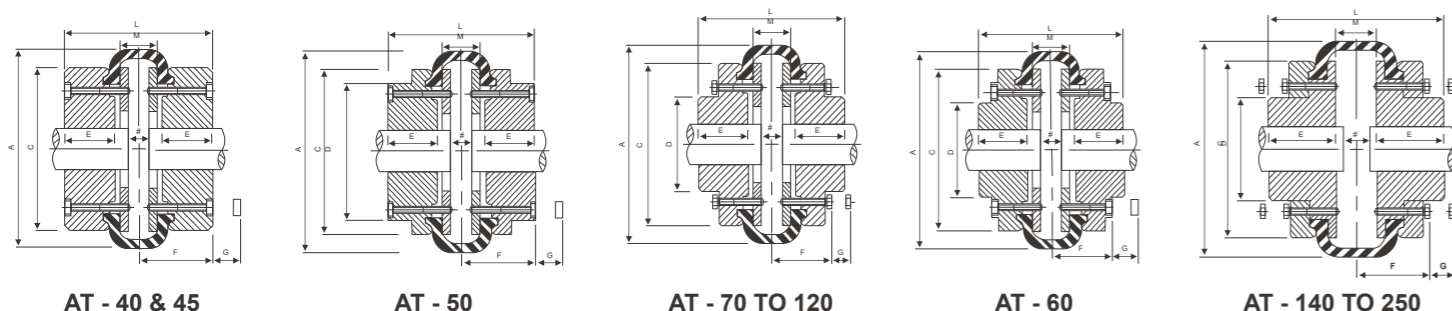

Size	Bore		Max. Speed (rev/min)	Coupling Rating @100 RPM	Torque (Nm)		Dimensions (mm)										Maximum Misalignment (mm)		
	Max Bore	Min Bore			Nominal	Max.	L	D	E	F	Set Screw on key	Approx Weight Kg	A	C	(ii) G	(iii) M	No. of screws per flange	Parallel	End float ±
AT-40	30	11	4500	0.22	21	64	67	-	22	33.5	M5	2	104	82	43	23	4	1.1	1.3
AT-45	32	11	4500	0.39	37	110	73	-	25	36.5	M5	2.2	120	94	43	23	4	1.2	1.5
AT-50	38	16	4500	0.56	53	160	92	79	32	46	M5	4	133.5	100	43	28	4	1.3	1.7
AT-60	48	16	4000	1.11	106	318	112	73	38	43	M6	5	165	125	43	36	5	1.6	2
AT-70	55	19.05	3600	1.7	162	487	132	82	45	50.5	M6	8	211	167	43	47	5	1.9	2.3
AT-80	65	25.4	3100	2.65	253	759	149	95	51	53	M10	12	222	179	10	47	6	2.1	2.6
AT-85	70	31.75	3000	3.2	305	915	154	103	53	53.5	M12	14	235	188	13	48	6	2.2	2.8
AT-90	76	31.75	2880	3.82	365	1096	164	110	57	59.5	M12	15	254	216	13	50	6	2.4	3
AT-100	85	31.75	2600	5.29	505	1517	178	124	60	61.5	M12	21	279	233	14	50	6	2.6	3.3
AT-110	90	31.75	2300	7.46	712	2137	180	134	65	63.5	M12	28	314	264	14	55	6	2.9	3.7
AT-120	102	38.1	2050	12.4	1182	3547	207	152	76	70	M12	41	359	313	14	26	6	3.2	4
AT-140	120	75	1800	19.7	1881	5642	204	195	89	76	M20	61	402	345	19	16	8	3.7	4.6
AT-160	140	75	1600	32.6	3113	9339	220	216	102	78	M20	86	470	398	19	30	10	4.2	5.3
AT-180	150	75	1500	57.4	5485	16455	258	266	114	94	M20	141	508	429	19	48	12	4.8	6
AT-200	150	75	1300	84	8022	23508	276	266	114	103	M20	179	562	474	20	56	12	5.3	6.6
AT-220	160	90	1100	104	9932	33125	312	267	127	118	M20	312	628	532	25	60	12	5.8	7.3
AT-250	190	100	1000	132	12606	42740	360	290	150	125	M20	500					12	6.6	8.2



## RESILIENT COUPLINGS

AniGears AR Series Resilient Couplings are high-performance, torsionally flexible couplings designed to provide an optimum balance of shock absorption, torsional flexibility, and positive torque transmission.

They transmit power through a specially contoured spring steel grid fitted between two precision-machined hubs and enclosed within a lubricated steel cover.

The grid flexes under load, absorbing shocks and torsional vibrations while accommodating limited angular, parallel, and axial misalignments.

This design combines the advantages of both rigid and flexible couplings, offering smooth power transmission and protection for connected equipment from sudden torque fluctuations.

AniGears AR Couplings are engineered for quiet operation, long life, and fail-safe performance, making them ideal for medium to heavy-duty drives.

All metallic components are phosphated to resist corrosion and to ensure excellent lubrication retention.

## Applications

AniGears AR Resilient Couplings are ideal for applications requiring flexibility, vibration damping, and smooth torque transmission.

Common uses include:

- ✓ Centrifugal and reciprocating pumps.
- ✓ Conveyors (belt, apron, bucket, screw).
- ✓ Fans and blowers.
- ✓ Crushers and mixers.
- ✓ Compressors and feeders.
- ✓ Extruders, agitators, and material-handling drives.
- ✓ Rolling mills and general mechanical drives.



## Construction & Materials

Component	Material / Specification	Function / Description
Hubs	Forged Carbon Steel (EN-8 / EN-9)	Machined with precision grid grooves for uniform torque transmission.
Grid Element	High-Tensile Spring Steel (Hardened & Shot Peened)	Acts as a flexible medium; transmits torque while damping vibration and shock.
Covers (Split / Solid Type)	Cast Steel (IS 1030) or Ductile Iron	Enclose the grid and retain lubrication. Split or solid designs available for ease of assembly.
Sealing Rings / Gaskets	Nitrile Rubber (NBR)	Prevent leakage of grease and ingress of dust or moisture.
Fasteners	High Tensile Steel (Grade 8.8), Zinc-Plated	Secure cover halves; corrosion-resistant.
Lubricant	Lithium-Based EP2 High-Temperature Grease	Ensures smooth grid movement and minimizes wear.
Surface Finish	Manganese / Zinc Phosphate Coating	Improves corrosion resistance, ensures strong oil adhesion, and enhances lubrication film retention.

**Note:**  
All AniGears AR Couplings are dynamically balanced, phosphated, and supplied pre-lubricated with grease for easy installation.

## Performance Characteristics

Parameter	AR Series
Nominal Torque Capacity	Up to 50,000 N·m
Speed Range	Up to 3,600 RPM
Angular Misalignment	± 0.25°
Parallel Misalignment	Up to 0.25 mm
Axial Float	± 1.5 mm
Service Factor Range	1.0 – 4.5
Temperature Range	-20 °C to +80 °C
Lubrication Type	Grease (EP2 or equivalent)

## Design & Operating Features

### Torsional Flexibility

The spring steel grid flexes under load, absorbing torsional vibrations and cushioning shock loads.

### Shock & Vibration Damping

Grid design effectively dampens sudden torque peaks, protecting connected machinery.

### Misalignment Compensation

Accommodates angular, parallel, and axial misalignments without excessive bearing or shaft stresses.

### Fail-Safe Performance

Even if the grid fails, metallic contact between hubs permits limited torque transmission to prevent drive interruption.

### Compact & Efficient Design

High torque capacity for compact dimensions; suitable for confined space installations.

### Ease of Maintenance

The grid can be replaced easily without moving connected machinery. Grease nipples allow quick relubrication.

### Fully Enclosed Lubrication

Grease-lubricated cover ensures quiet operation and long service life by preventing dust or moisture entry.

### Phosphated Finish

All metallic parts are phosphated, not painted or CED-coated, to ensure compatibility with grease lubrication and to resist corrosion while retaining lubricant.

## Guidelines for Selection of Coupling

- ✔ **Step 1 — Determine Service Factor (SF)** Select SF from the above table based on application and prime mover.
- ✔ **Step 2 — Calculate Design Power (P<sub>d</sub>)** Design Power (kW)=Absorbed Power (kW)×Service Factor (SF)
- ✔ **Step 3 — Select Coupling Size** From the combined Power & Dimension Table, choose the coupling whose rated power at operating speed is ≥ Design Power.
- ✔ **Step 4 — Verify Shaft Bore Range** Ensure both shaft diameters fall within the permissible bore range of the selected size.
- ✔ **Step 5 — Confirm Speed and Misalignment** Check that actual operating speed and misalignment are within rated limits.

## Service Factor Table

Use these Service Factors (SF) with absorbed power to calculate the Design Power (kW) for coupling selection.

Type of Driven Equipment	Nature of Load	Service Factor (SF)
Centrifugal Pumps, Fans, Blowers	Uniform	1.0 – 1.3
Conveyors (belt, apron, horizontal)	Light Shock	1.3 – 1.5
Mixers, Agitators, Rotary Pumps	Moderate	1.5 – 1.8
Crushers, Compressors, Hammer Mills	Heavy	1.8 – 2.5
Vibrating Screens, Reciprocating Pumps, Rolling Mills	Severe	2.5 – 3.5
Hoists, Crushers (ore/stone), Reversing Drives	Very Severe	3.5 – 4.5

## Installation Steps

- ✓ Clean all components before assembly.
- ✓ Mount hubs on shafts with proper key fits.
- ✓ Align hubs and maintain specified spacing between them.
- ✓ Insert grid into the hub grooves and pack with grease.
- ✓ Fit cover halves ensuring gasket seals properly.
- ✓ Tighten bolts evenly and diagonally.
- ✓ Verify alignment post-assembly.

## Lubrication

- ✓ Use Lithium-based EP2 grease or equivalent.
- ✓ Fill approximately 75% of cavity volume.
- ✓ Re-lubricate every 3,000–4,000 operating hours or as per maintenance schedule.

## Maintenance

- ✓ Inspect grid periodically for cracks, wear, or deformation.
- ✓ Replace seals if hardened or damaged.
- ✓ Maintain proper grease level to ensure smooth, quiet operation.
- ✓ Keep the coupling area free of dirt, oil, or solvents.

## Notes

- ✓ Ratings are based on continuous duty at ambient temperatures up to 50 °C.
- ✓ For reversing or high-shock applications, multiply absorbed power by the appropriate SF.
- ✓ For speeds below 100 RPM, torque values govern selection.
- ✓ Maintain alignment within 50% of permissible limits for extended life.
- ✓ Phosphate coating provides rust protection and enhances lubrication retention — do not paint or CED coat.
- ✓ For vertical or special-duty applications, consult AniGears Technical Department.

## Dimensions

### TYPE - Z

( for use on horizontal shafts only )

Coupling Size	Rating H.P./RPM	Clear Diameter OD (mm)	Boss Length L1 (mm)	Boss Length L2 (mm)	Removal Space RS (mm)	Gap G (mm)	Cover Bore CB (mm)	Safe Speed R.P.M	Stock Rough Bore (mm)	Max. Bore (mm)	Approx. Weight Kgs
AR-101	0.006	105.00	38.00	38.00	52.00	0.85	44.52	5650	10	29	3
AR-102	0.010	120.50	38.00	38.00	52.00	0.85	58.80	4750	12	38	4
AR-103	0.020	144.50	44.50	44.50	59.00	0.85	62.00	4450	16	41	5
AR-104	0.030	171.50	51.00	51.00	59.00	0.85	87.45	3400	16	57	9
AR-106	0.045	190.50	51.00	51.00	79.00	0.85	84.25	3200	16	54	11
AR-107	0.065	197.00	57.00	57.00	79.00	0.85	96.95	2950	16	64	15
AR-108	0.095	222.00	63.50	63.50	79.00	0.85	119.20	2500	25	78	20
AR-109	0.125	254.00	70.00	70.00	80.00	0.85	143.00	2150	25	92	27
AR-110	0.185	276.00	89.00	89.00	80.00	0.85	165.20	1900	25	108	43
AR-111	0.355	295.00	102.00	102.00	128.00	1.60	155.70	1800	38	102	54
AR-113	0.455	324.00	101.50	101.50	147.00	1.60	187.46	1650	50	123	63
AR-114	0.655	336.50	101.50	101.50	147.00	1.60	184.28	1550	50	121	72
AR-115	0.905	375.00	114.00	114.00	147.00	1.60	222.38	1350	50	146	104
AR-117	1.255	425.50	127.00	127.00	147.00	1.60	254.00	1200	50	167	149

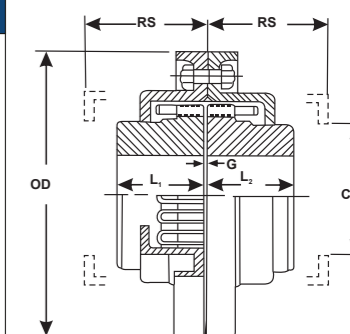

**Type - Z**  
Size:AR-101 to AR-117

### TYPE - Y

( for use on horizontal shafts only )

Coupling Size	Rating H.P./RPM	Clear Diameter OD (mm)	Boss Length L1 (mm)	Boss Length L2 (mm)	Removal Space RS (mm)	Gap G (mm)	Cover Bore CB (mm)	Safe Speed R.P.M	Stock Rough Bore (mm)	Max. Bore (mm)	Approx. Weight Kgs
AR-120	1.755	432.00	140.00	140.00	179.00	3.20	239.50	1200	75	157	175
AR-121	2.405	432.00	140.00	140.00	179.00	3.20	239.50	1200	75	157	180
AR-122	2.755	492.00	152.50	152.50	179.00	3.20	266.70	1100	85	173	207
AR-123	3.505	492.00	152.50	152.50	179.00	3.20	266.70	1100	85	173	216

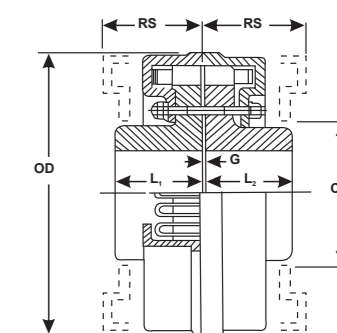

**Type - Y**  
Size :AR-120 to AR-123

# ANIJAW COUPLINGS (AJ SERIES)



AniGears AJ Series Jaw Couplings are torsionally flexible, fail-safe couplings designed to transmit torque through interlocking precision-machined jaws and a resilient elastomer element (spider).

They provide reliable power transmission while absorbing shock loads and damping vibration.

The design ensures continuous drive even in case of elastomer failure (metal-to-metal contact between jaws), making them ideal for industrial applications where reliability and simplicity are essential.

AniGears Jaw Couplings are compact, easy to install, and require no lubrication, offering long life with minimal maintenance.

They are suitable for both horizontal and vertical installations, and are widely used across mechanical drives where moderate torque, flexibility, and vibration damping are required.

The AJ Series is available in four variants to suit diverse mounting and maintenance requirements:

Model	Description
<b>AJ Type</b>	Standard Jaw Coupling – general-purpose use
<b>AJW Type</b>	Split elastomer element (Snap Wrap) – easy replacement without disturbing hubs
<b>AJL Type</b>	Radially Removable AJ Type – elastomer can be replaced radially without moving hubs
<b>AJS Type</b>	Spacer version – suitable for pumps and applications requiring axial separation

## Applications

AniGears AJ Series Jaw Couplings are widely used in:

- ✓ Pumps and compressors
- ✓ Fans and blowers
- ✓ Conveyors and mixers
- ✓ Machine tools and gearboxes
- ✓ Printing, textile, and packaging machinery
- ✓ General mechanical and OEM drives

## Construction & Materials

Component	Material / Specification	Function / Description
Hubs	High Grade Cast Iron (IS 210 FG 260) / Cast Steel	Precision-machined jaws ensure accurate engagement and torque transmission.
Elastomer (Spider Element)	Polyurethane (PU) / Nitrile Rubber (NR)	Absorbs shock, accommodates misalignment, and dampens vibration. Available in various hardness grades.
Fasteners / Clamping Rings	High Tensile Steel (Grade 8.8), CED-Coated	Provide secure locking of hubs and corrosion protection.
Spacer (AJS Type)	Machined Mild Steel or Aluminium	Allows greater axial distance between shafts; ideal for pump drives.
Surface Finish	Cathodic Electrode Deposition (CED)	Ensures superior corrosion resistance and consistent finish.
Lubrication	Not Required	Dry-type coupling; maintenance-free operation.

**Note:**

All AniGears Jaw Couplings are supplied pre-machined and dynamically balanced. The elastomer element is resiliently preloaded between the jaws for zero backlash under normal operation.

## Service Factor Table

Type of Driven Equipment	Nature of Load	Service Factor (SF)
Centrifugal Pumps, Fans, Blowers	Uniform	1.0 – 1.3
Conveyors, Agitators, Mixers	Moderate Shock	1.4 – 1.6
Crushers, Compressors, Hammer Mills	Heavy	1.8 – 2.2
Vibrating Screens, Reciprocating Pumps	Severe	2.3 – 2.8
Hoists, Crushers (Stone/Ore), Reversing Drives	Very Severe	3.0 – 3.5

**Note:**

- ✓ Add 0.25 for I.C. engine drives.
- ✓ Add 10% for duty exceeding 10 hours/day.
- ✓ For frequent start/stop or reversing applications, select the next higher coupling size.

## Selection Procedure

- ✓ **Step 1 – Determine Absorbed Power (kW)**  
Obtain absorbed power from the driven machine or calculate from torque and speed.
- ✓ **Step 2 – Select Service Factor (SF)**  
Refer to the Service Factor table and choose the appropriate SF based on application.
- ✓ **Step 3 – Compute Design Power**  
Design Power=Absorbed Power×Service Factor.
- ✓ **Step 4 – Determine Coupling Rating at Operating Speed**  
Rated kW scales directly with speed: Rated kW at N rpm=kW at 100 rpm × N/100 (use table values for kW@100 rpm).
- ✓ **Step 5 – Select Coupling Size**  
Choose the smallest coupling whose Rated Power ≥ Design Power at operating speed.
- ✓ **Step 6 – Verify Bore and Misalignment**  
Confirm both shafts are within permissible bore range and misalignment limits.
- ✓ **Step 7 – Finalize Coupling Type**  
  - AJ Type** – Standard, general purpose
  - AJW Type** – Snap Wrap, easy elastomer replacement
  - AJL Type** – Radially removable, no hub movement
  - AJS Type** – Spacer type for pumps/fans requiring axial separation

## Performance Characteristics

Parameter	AJ Series (All Types)
Nominal Torque Capacity	Up to 150,000 N·m
Speed Range	Up to 6,000 RPM
Angular Misalignment	Up to ±1°
Parallel Misalignment	Up to 0.25 mm
Axial Float	Up to ±1 mm
Temperature Range	–40 °C to +90 °C
Service Factor Range	1.0 – 3.0
Lubrication	Not required

## Design & Operating Features

### Compact and Simple Construction

Two hubs and one elastomer spider form a light, compact, and easily assembled coupling.

### Torsional Flexibility

The spider deflects under load, damping vibration and absorbing shock.

### Misalignment Capability

Handles small angular, parallel, and axial misalignments.

### Ease of Maintenance

Elastomer can be replaced without disturbing connected machinery (for AJW, AJL, and AJS types).

### No Lubrication Required

Operates dry and clean.

### Corrosion-Protected Hardware

All metallic components are CED-coated for long-term rust resistance.

### Multiple Variants

Standard, snap-wrap, radial, and spacer types cover diverse installation needs.

## Installation Steps

- ✓ Clean all components thoroughly before assembly.
- ✓ Mount hubs on shafts ensuring full key engagement.
- ✓ Align shafts and maintain equal gap between hub jaws.
- ✓ Insert the elastomer spider ensuring full seating between jaws.
- ✓ For AJW / AJL / AJS types, ensure clamping rings or fasteners are securely tightened.
- ✓ Check alignment after installation.

## Maintenance

- ✓ Periodically inspect elastomer for wear, cracks, or hardening.
- ✓ Replace if swelling, tearing, or excessive wear is observed.
- ✓ Recheck alignment periodically.
- ✓ No lubrication required.

## Additional Notes

- ✓ All AniGears AJ Couplings operate dry and are maintenance-free.
- ✓ Elastomers are oil-resistant polyurethane (standard); alternate hardness available on request.
- ✓ For high-vibration or vertical applications, consult AniGears Technical Department.
- ✓ All metallic components are CED-coated for corrosion protection.

## Dimensions AJ, AJW, AJS

Coupling	Power Rating					Pilot Bore	Max. Bore D	ØA		Length thru' Bore L1	ØB	Gap G	ØE	DBSE	Overall Length TL1
	Type	Size	Rated Torque (Nm)	kW@ 100rpm	Rated Torque (Nm)			kW@ 100rpm	AJW/AJS						
AJ AJW AJS	95	21.1	0.22	31.7	0.33	-	28	65	54	25	49	2	19	90, 100,	63
	100	46.4	0.49	69.6	0.73	-	35	78	65	35	57	2	27	140	88
	110	89	0.93	133.5	1.4	-	42	96	85	43	76	3	35		108
	150	141	1.5	211.5	2.2	-	48	111	96	45	80	3	35	90, 100,	115
	190	190	2	285	3	-	60	129	115	54	102	3	45	140, 180	133
	225	265	2.8	397.5	4.2	-	65	142	127	64	111	3	45		153
AJ AJW	226	327	3.4	490.5	5.1	25	70	153	137	70	119	3	51		178
	276	532	5.6	798	8.4	25	75	173	157	80	127	3	60	-	200
	280	782	8.2	1173	12.3	30	80	208	192	80	140	3	70	-	200
	295	1279	13.4	1918.5	20.1	30	95	253	237	95	162	3	80	-	238

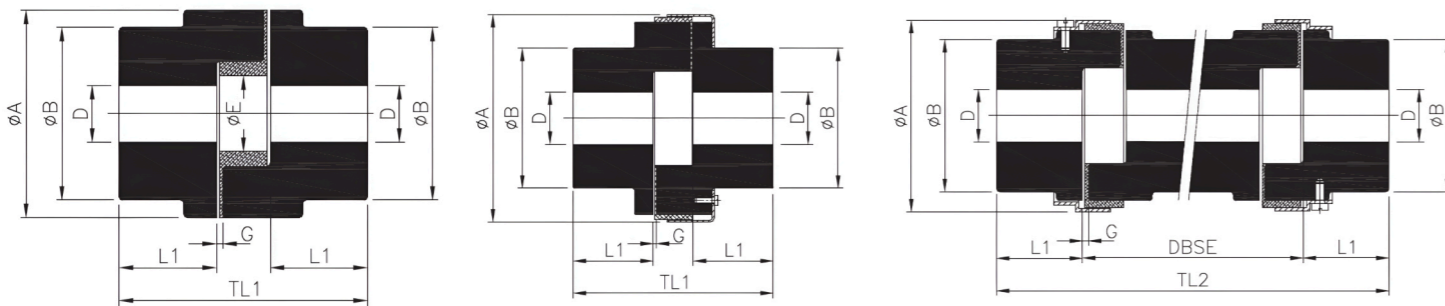

## Dimensions AJL

Coupling Size	Synthetic Rubber		DBSE		Bore ØD		Outside Dia ØA	Adapter Hub Dia ØB	Length thru' Bore "L"	Min. Bolt Clearance 'M'		Total Length 'TL'
	kW at 100 rpm	Rated Torque (Nm)	Min.	Std.	Min.	Max.				Std.		
AJL 95	0.22	21	75	90, 100,	10	28	54	54	25	-	45	140,150,190
AJL 100	0.49	46		140		38	65	65	30	-	50	150,160,200
AJL 110	0.93	89		90		42	85	76	35	36	60	160,170,210,250
AJL 150	1.5	141	15	100	15	48	96	90	40	48	70	170,180,220,260
AJL 190	2	190		140		55	115	102	45	48	75	180,190,230,270
AJL 225	2.8	265		180		65	127	115	50	54	90	190,200,240,280

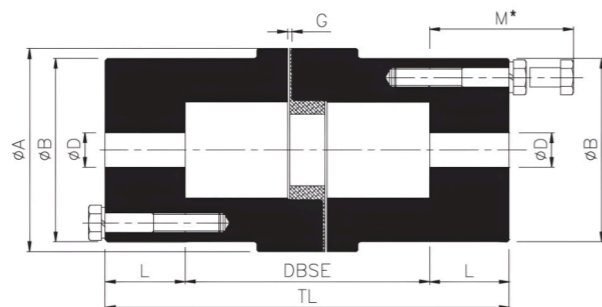

## Our Esteemed Customers

AniGears™ Engineering Solutions is a leading Indian manufacturer engaged in the design, development, and production of mechanical power transmission and material handling products, specializing in industrial couplings, pulleys, and conveyor components.

Engineered with Pride, Made in India.



## Our Certificates

AniGears™ Engineering Solutions is proudly certified with ISO 9001:2015 for quality management excellence and registered under MSME, reflecting our commitment to superior standards, innovation, and trusted Indian manufacturing.



# Thank You! for Your Trust!

We sincerely appreciate your confidence in **AniGears™** Engineering Solutions. Your trust drives our commitment to deliver precision, innovation, and quality — powering industries, empowering progress.

## AniGears™ Engineering Solutions



+91 81002 25530 | 31



works@anigears.com



www.anigears.com



Works Unit I: Howrah, West Bengal  
Works Unit II: Ahmedabad, Gujarat  
Works Unit III: Nagpur, Madhya Pradesh

Scan Me

